

閥調式鉛酸蓄電池(VRLA)

PL250-12HB (12V250AH)

規格 Type

額定電壓 Rated Voltage	12V	
額定容量 Rated Capacity	250.0AH/20Hr/10.5V	端子 Terminal: 螺栓(M8 Bolt)
尺寸 Dimension	長度 Length	480±1mm(18.90in)
	寬度 Width	250±1mm(9.84in)
	高度 Height	244±1mm(9.61in)
	總高度 Total Height	244±1mm(9.61in)
重量 Weight	68.0kg(149.6Pounds)	
電槽材質 Container Material	ABS, UL 94V-0 or UL 94-HB 抗酸、抗油、防震 Resist acid, resist oil, resist vibration	氧氣指數 Index of oxygen L.O.I>28%
電解液型式 Type of electrolyte	AGM 不外漏 Non-spillable	凝膠型 Gel Type



特性 Properties

容量 Capacity 25°C (77°F)	20 小時率 20HR of 12.5A to 10.5V	250.0AH
	5 小時率 5HR of 40.5A to 10.5V	202.5AH
	1 小時率 1HR of 162.5A to 10.5V	162.5AH
	0.5 小時率 0.5HR of 263.0A to 10.5V	131.5AH
內阻 Internal Resistance (at 1KHz)	完全充電 Full Charge at 25°C (77°F)	大約 Approx.2.70mΩ
容量受溫度影響 The capacity will be effected by temperature	40°C (104°F)	105%(20HR to 262AH)
	25°C (77°F)	100%(20HR to 250AH)
	0°C (32°F)	85%(20HR to 212AH)
	-20°C (-4°F)	60%(20HR to 150AH)
自我放電 Self-discharge	180 天後不到 15%，可以在 20°C (68°F) 下保存 8 個月；使用前需要完全充電。 Less than 15% after 180 days, it can be stored at 20°C (68°F) for 8 months; it needs to be fully charged before use.	
最大放電電流 5 秒 Maximum Discharge Current at 5 Sec	1625.0A(6.5CA)	
冷啟動電流 Cold start current (-18°C)	900A	
浮充 Float Charging	電壓 Voltage	13.65±0.15V 25°C (77°F)
	電流 Current	75.00A(0.3CA)
循環充電 Cyclic Charging	電壓 Voltage	14.70±0.30V 25°C (77°F)
	電流 Current	62.50A(0.25CA)
操作溫度 Operation Temperature Range	充電 Charge/放置 Storage:-15~40°C (5~104°F)，放電 Discharge:-20~50°C (-4~122°F)	
期待壽命 Expected Life	25°C (77°F) 8~10 years	

尺寸 Dimension: inch (mm)

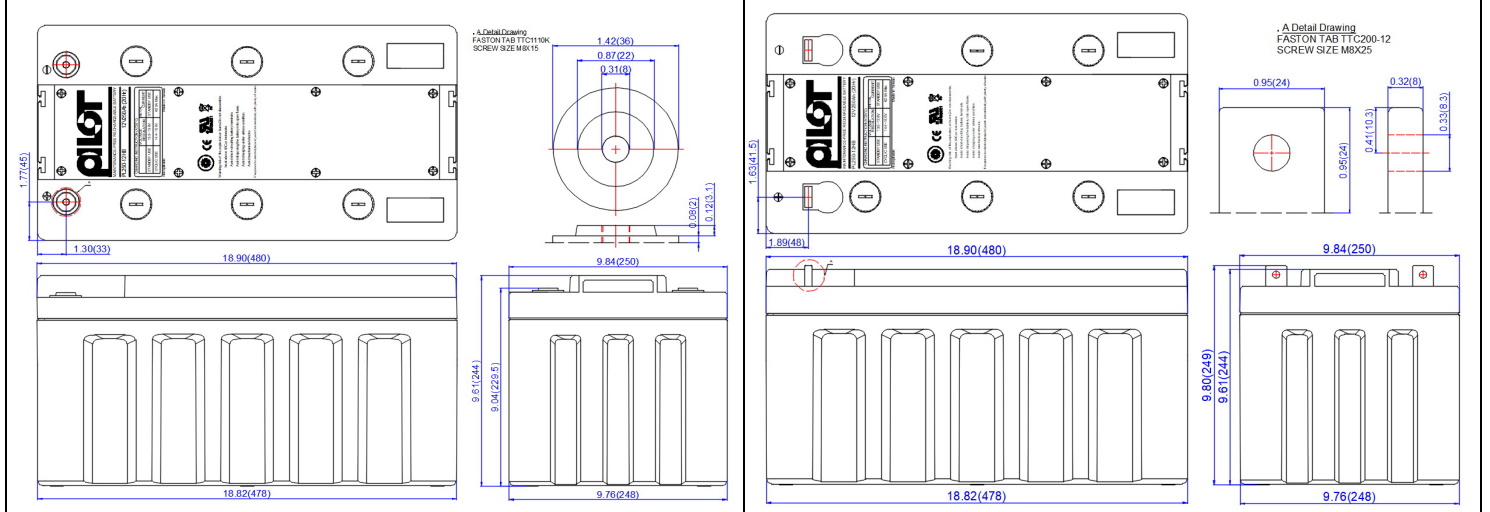

PL250-12HB PROPERTIES

Amperes and watts per battery at 25°C (77°F)

F.V.	Time	Minutes									Hours							
	Item	5	10	15	20	25	30	35	40	45	1	2	3	4	5	8	10	20
1.60 (9.60)	A	755	558	453	398	333	298	270	250	228	175.0	100.0	70.0	55.0	44.5	29.1	25.5	14.0
	W	7928	5854	4978	4373	3824	3421	3105	2875	2616	2013	1170	819	644	534	349	306	168
1.65 (9.90)	A	693	515	425	370	315	280	255	235	215	170.0	98.8	69.2	53.8	44.0	28.4	25.0	13.8
	W	7271	5408	4675	4070	3623	3220	2933	2703	2473	1955	1155	809	629	528	341	300	165
1.70 (10.20)	A	665	478	400	348	300	270	245	223	210	165.0	96.3	67.5	51.9	43.0	27.8	23.5	13.0
	W	6983	5014	4400	3823	3450	3105	2818	2559	2415	1898	1126	790	607	516	334	282	156
1.75 (10.50)	A	630	438	373	330	288	263	235	215	200	162.5	91.3	63.3	49.4	40.5	27.2	22.5	12.5
	W	6615	4594	4098	3630	3306	3019	2703	2473	2300	1869	1068	741	578	486	326	270	150
1.80 (10.80)	A	570	398	340	303	273	245	225	205	195	157.5	87.5	62.5	48.1	39.5	26.3	22.0	12.3
	W	5985	4174	3740	3328	3134	2818	2588	2358	2243	1811	1024	731	563	474	315	264	147
1.83 (10.98)	A	525	315	293	253	233	218	195	175	168	150.0	86.3	59.2	45.6	37.0	25.6	20.5	11.5
	W	5513	3308	3218	2778	2674	2501	2243	2013	1926	1725	1009	692	534	444	308	246	138

用途 Application	密封結構 Seal construction	穩定性 Stabilities
<ul style="list-style-type: none"> ☆UPS 緊急備用電源 UPS emergency backup power ☆通信系統 Communication back-up systems ☆電力系統 Power systems ☆太陽能儲備系統 Solar storage power systems ☆緊急照明 Emergency lighting 	<ul style="list-style-type: none"> ☆沒有漏酸的危險，氣體釋放率超低，不需加水，能防止電解液乾枯或產生層化現象(於放電時)再組合率大於98% Non-spillable, no leaking danger, the gas consumption rate is low, no need to replenish water, can avoid acid lack or crystallization problem during discharge, the recombination rate is higher than 98% ☆極柱採用鉛錫合金或合金銅鍍鉛材質 The polarities adopted Antimony-Lead alloy or copper alloy covered with Lead material. 	<ul style="list-style-type: none"> ☆正負極板是鉛鈣合金 Positive, negative's plates are all Calcium-Lead alloy. ☆塑殼是防火 ABS 或等級是 UL 94V-0 L.O.I>28% The plastic material is fire-resistance ABS or same grade of UL 94V-0 L.O.I >28% ☆組立用螺絲採用 M8 螺絲，扭力從 7N-m 至 10N-m(最大)採用不銹鋼材質，堅固耐用。 Assembling screws using M8 screws, torque from 7N-m to 10N-m (maximum) made of stainless steel, durable.

放電特性(25°C) Discharge characteristic at different rates(25°C)	定電壓充電(25°C) Charging Characteristics	浮充期待壽命 Float Service Life
---	---	------------------------------

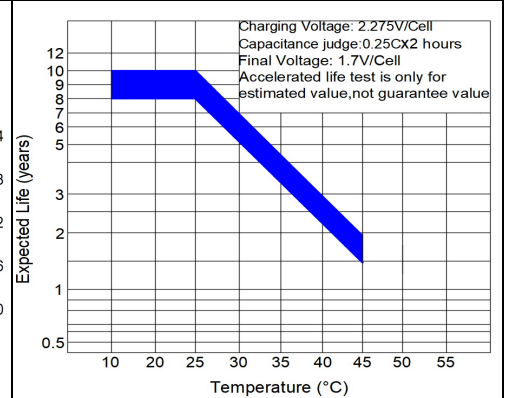
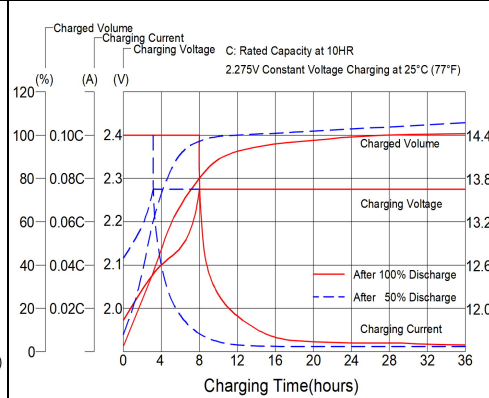
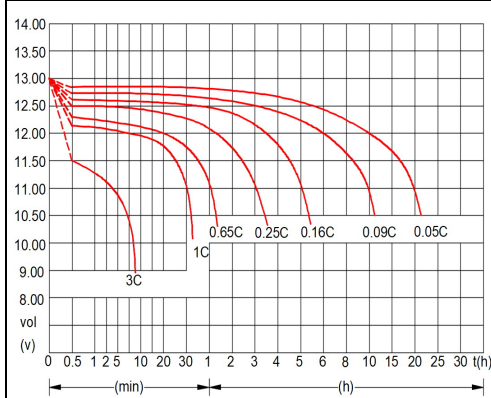

溫度與充電電壓關係 Relationship Between Temperature And Charging Voltage	容量保持特性 Capacity Retention Characteristics	壽命循環關係 Cycle Service Life
--	--	------------------------------

