

閥調式鉛酸蓄電池(VRLA)

PL65-12 (12V65AH)

規格 Type

額定電壓 Rated Voltage	12V	
額定容量 Rated Capacity	65.0AH/20Hr/10.5V	端子 Terminal: 螺栓(M6 Bolt)
尺寸 Dimension	長度 Length	350±1mm(13.78in)
	寬度 Width	166±1mm(6.54in)
	高度 Height	174±1mm(6.85in)
	總高度 Total Height	174±1mm(6.85in)
重量 Weight	20.5kg(45.1 Pounds)	
電槽材質 Container Material	ABS, UL 94V-0 or UL 94-HB 抗酸、抗油、防震 Resist acid, resist oil, resist vibration	氧氣指數 Index of oxygen L.O.I>28%
電解液型式 Type of electrolyte	AGM 不外漏 Non-spillable	



特性 Properties

容量 Capacity 25°C (77°F)	20 小時率 20HR of 3.25A to 10.5V	65.0AH
	5 小時率 5HR of 10.50A to 10.5V	52.5AH
	1 小時率 1HR of 42.30A to 10.5V	42.3AH
	0.5 小時率 0.5HR of 68.30A to 10.5V	34.1AH
內阻 Internal Resistance (at 1KHz)	完全充電 Full Charge at 25°C (77°F)	大約 Approx.6.0mΩ
容量受溫度影響 The capacity will be effected by temperature	40°C (104°F)	105%(20HR to 68.3AH)
	25°C (77°F)	100%(20HR to 65.0AH)
	0°C (32°F)	85%(20HR to 55.3AH)
	-20°C (-4°F)	60%(20HR to 39.0AH)
自我放電 Self-discharge	180 天後不到 20%，可以在 20°C (68°F) 下保存 6 個月；使用前需要完全充電。 Less than 20% after 180 days, it can be stored at 20°C (68°F) for 6 months; it needs to be fully charged before use.	
最大放電電流 5 秒 Maximum Discharge Current at 5 Sec	650.0A(10CA)	
浮充 Float Charging	電壓 Voltage	13.65±0.15V 25°C (77°F)
	電流 Current	19.50A(0.3CA)
循環充電 Cyclic Charging	電壓 Voltage	14.70±0.30V 25°C (77°F)
	電流 Current	16.25A(0.25CA)
操作溫度 Operation Temperature Range	充電 Charge/放置 Storage:-15~40°C (5~104°F), 放電 Discharge:-20~50°C (-4~122°F)	
期待壽命 Expected Life	25°C (77°F) 6~8 years	

尺寸 Dimension: inch (mm)

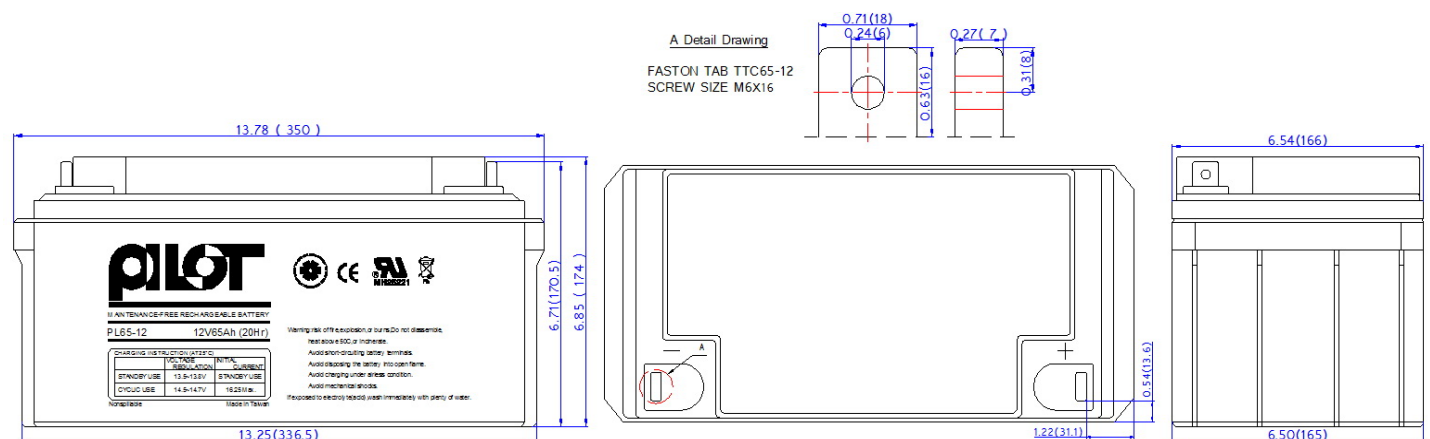

PL65-12 PROPERTIES

Amperes and watts per battery at 25°C (77°F)

F.V.	Time	Minutes										Hours							
	Item	1	5	10	15	20	25	30	35	40	45	1	2	3	4	5	8	10	20
1.60 (9.60)	A	309.4	196.3	145.0	117.7	103.4	86.5	77.4	70.2	65.0	59.2	45.5	26.0	18.2	14.3	11.6	7.6	6.6	3.6
	W	3249	2061	1522	1294	1137	994	890	807	748	680	523	304	213	167	139	91	80	44
1.65 (9.90)	A	272.4	180.1	133.9	110.5	96.2	81.9	72.8	66.3	61.1	55.9	44.2	25.7	18.0	14.0	11.4	7.4	6.5	3.6
	W	2860	1891	1406	1216	1058	942	837	762	703	643	508	300	210	164	137	89	78	43
1.70 (10.20)	A	247.0	172.9	124.2	104.0	90.4	78.0	70.2	63.7	57.9	54.6	42.9	25.0	17.6	13.5	11.2	7.2	6.1	3.4
	W	2594	1815	1304	1144	994	897	807	733	665	628	493	293	205	158	134	87	73	41
1.75 (10.50)	A	216.5	163.8	113.8	96.9	85.8	74.8	68.3	61.1	55.9	52.0	42.3	23.7	16.5	12.8	10.5	7.1	5.9	3.3
	W	2273	1720	1194	1065	944	860	785	703	643	598	486	278	193	150	126	85	70	39
1.80 (10.80)	A	191.8	148.2	103.4	88.4	78.7	70.9	63.7	58.5	53.3	50.7	41.0	22.8	16.3	12.5	10.3	6.8	5.7	3.2
	W	2013	1556	1085	972	865	815	733	673	613	583	471	266	190	146	123	82	69	38
1.83 (10.98)	A	178.8	136.5	81.9	76.1	65.7	60.5	56.6	50.7	45.5	43.6	39.0	22.4	15.4	11.9	9.6	6.7	5.3	3.0
	W	1877	1433	860	837	722	695	650	583	523	501	449	262	180	139	115	80	64	36

用途 Application	密封結構 Seal construction	穩定性 Stabilities
<ul style="list-style-type: none"> ☆廣播電視系統 Broadcast television systems ☆UPS 緊急備用電源 UPS emergency backup power ☆通信系統 Communication back-up systems ☆電力系統 Power systems ☆緊急照明器材 Emergency lighting equipment ☆防火、保全系統 Fire, security systems 	<ul style="list-style-type: none"> ☆沒有漏酸的危險，氣體釋放率超低，不需加水，能防止電解液乾枯或產生層化現象(於放電時)再組合率大於98% Non-spillable, no leaking danger, the gas consumption rate is low, no need to replenish water, can avoid acid lack or crystallization problem during discharge, the recombination rate is higher than 98% ☆極柱採用鉛錫合金或合金銅鍍鉛材質 The polarities adopted Antimony-Lead alloy or copper alloy covered with Lead material. 	<ul style="list-style-type: none"> ☆正負極板是鉛鈣合金 Positive, negative's plates are all Calcium-Lead alloy. ☆塑殼是防火 ABS 或等級是 UL 94V-0 L.O.I>28% The plastic material is fire-resistance ABS or same grade of UL 94V-0 L.O.I >28% ☆組立用螺絲採用 M6 螺絲，扭力從 5N-m 至 8N-m(最大)採用不銹鋼材質，堅固耐用。 Assembling screws using M6 screws, torque from 5N-m to 8N-m (maximum) made of stainless steel, durable.

放電特性(25°C) Discharge characteristic at different rates(25°C)	定電壓充電(25°C) Charging Characteristics	浮充期待壽命 Float Service Life
---	---	------------------------------

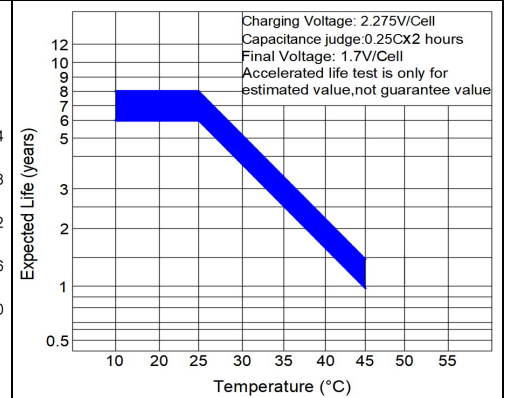
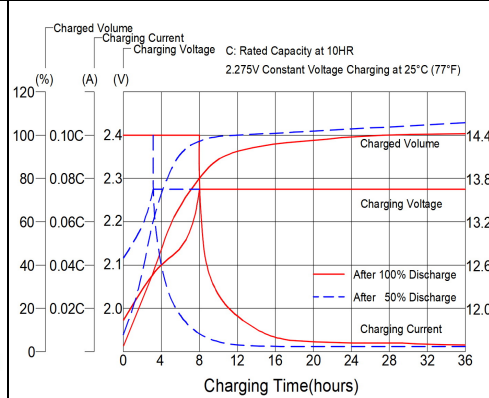
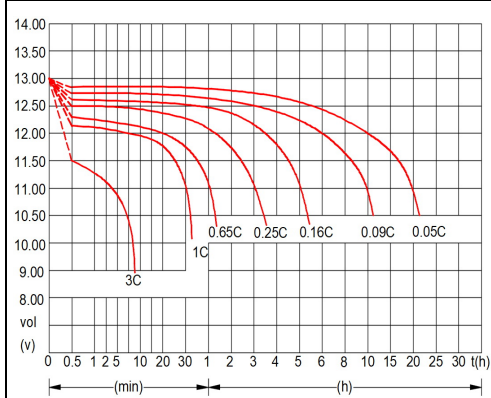

溫度與充電電壓關係 Relationship Between Temperature And Charging Voltage	容量保持特性 Capacity Retention Characteristics	壽命循環關係 Cycle Service Life
--	--	------------------------------

