

# 閥調式鉛酸蓄電池(VRLA)

## PMU2500S (2V500AH)

### 規格 Type

額定電壓 Rated Voltage	2V	
額定容量 Rated Capacity	500.0AH/10Hr/1.80V	端子 Terminal: 螺栓(M8 Bolt)
尺寸 Dimension	長度 Length	211±1mm(8.31in)
	寬度 Width	176±1mm(6.93in)
	高度 Height	330±1mm(12.99in)
	總高度 Total Height	367±1mm(14.45in)
重量 Weight	29.1kg(64.02Pounds)	
電槽材質 Container Material	ABS, UL 94V-0 or UL 94-HB 抗酸、抗油、防震 Resist acid, resist oil, resist vibration	氧氣指數 Index of oxygen L.O.I>28%
電解液型式 Type of electrolyte	AGM 不外漏 Non-spillable	



### 特性 Properties

容量 Capacity 25°C(77°F)	10 小時率 10HR of 50.0A to 1.80V	500.0AH
	5 小時率 5HR of 85.0A to 1.80V	425.0AH
	1 小時率 1HR of 265.0A to 1.80V	265.0AH
	0.5 小時率 0.5HR of 390.0A to 1.80V	195.0AH
內阻 Internal Resistance (at 1KHz)	完全充電 Full Charge at 25°C(77°F)	大約 Approx.0.48mΩ
容量受溫度影響 The capacity will be effected by temperature	40°C(104°F)	105%(10HR to 525AH)
	25°C(77°F)	100%(10HR to 500AH)
	0°C(32°F)	85%(10HR to 425AH)
	-20°C(-4°F)	60%(10HR to 300AH)
自我放電 Self-discharge	180 天後不到 15%，可以在 20°C (68°F) 下保存 10 個月；使用前需要完全充電。 Less than 15% after 180 days, it can be stored at 20°C (68°F) for 10 months; it needs to be fully charged before use.	
最大放電電流 5 秒 Maximum Discharge Current at 5 Sec	2250.0A(4.5CA)	
浮充 Float Charging	電壓 Voltage	2.275±0.025V 25°C(77°F)
	電流 Current	150.0A(0.3CA)
循環充電 Cyclic Charging	電壓 Voltage	2.40±0.05V 25°C(77°F)
	電流 Current	125.0A(0.25CA)
操作溫度 Operation Temperature Range	充電 Charge/放置 Storage:-15~40°C(5~104°F) · 放電 Discharge:-20~50°C(-4~122°F)	
期待壽命 Expected Life	25°C(77°F) 10~12 years	

### 尺寸 Dimension: inch (mm)

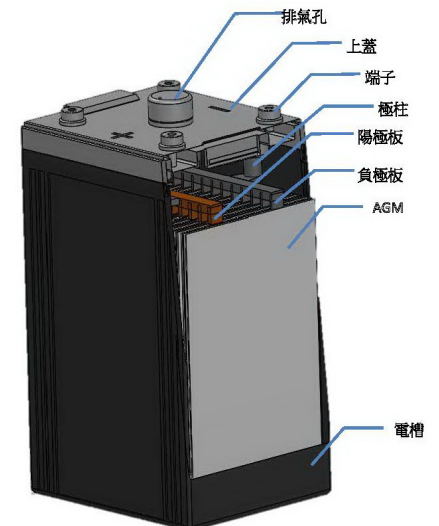
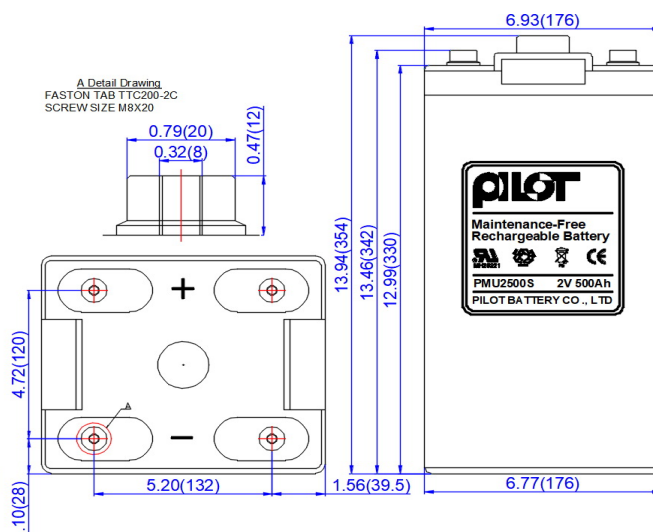
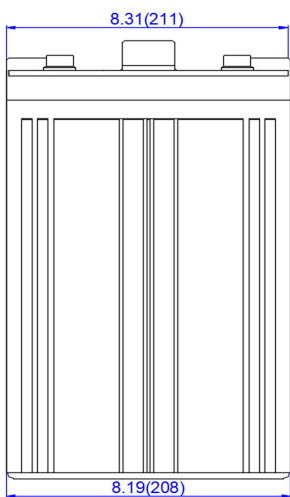

# PMU2500S PROPERTIES

Amperes and watts per battery at 25°C (77°F)

F.V.	Time	Minutes				Hours						
	Item	30	35	40	45	1	2	3	4	5	8	10
1.60	A	537.5	490.0	450.0	400.0	324.0	192.0	143.0	114.0	95.5	67.5	55.5
	W	959	894	825	736	605	366	273	218	183	130	107
1.65	A	511.5	460.0	420.0	380.0	315.5	185.0	137.0	110.0	94.5	66.0	54.5
	W	935	846	776	705	593	354	263	212	183	127	106
1.70	A	497.5	440.0	405.0	370.0	304.0	182.0	134.0	109.0	93.0	64.0	53.0
	W	916	813	756	698	574	348	258	210	180	124	103
1.75	A	431.0	420.0	380.0	350.0	280.0	176.0	132.5	107.0	90.0	62.5	52.0
	W	801	785	712	658	531	337	256	208	158	122	102
1.80	A	390.0	375.0	360.0	325.0	265.0	164.0	125.0	102.0	85.0	60.0	50.0
	W	727	702	677	613	505	316	242	198	165	117	99
1.83	A	350.0	325.0	300.0	275.0	244.0	155.0	116.0	94.0	79.0	55.0	47.0
	W	665	620	577	534	469	302	226	184	155	108	93

用途 Application	密封結構 Seal construction	穩定性 Stabilities
<ul style="list-style-type: none"> <li>☆廣播電視系統 Broadcast television systems</li> <li>☆電信和 UPS 系統 Telecom and UPS systems</li> <li>☆通信系統 Communication back-up systems</li> <li>☆太陽能儲備系統 Solar storage power systems, wind power systems</li> <li>☆電力系統 Power systems</li> <li>☆緊急照明 Emergency lighting</li> <li>☆火災安全系統 Fire and security systems</li> </ul>	<ul style="list-style-type: none"> <li>☆沒有漏酸的危險，氣體釋放率超低，不需加水，能防止電解液乾枯或產生層化現象(於放電時)再組合率大於 98%</li> <li>Non-spillable, no leaking danger, the gas consumption rate is low, no need to replenish water, can avoid acid lack or crystallization problem during discharge, the recombination rate is higher than 98%</li> <li>☆極柱採用鉛錫合金或合金銅鍍鉛材質 The polarities adopted Antimony-Lead alloy or copper alloy covered with Lead material.</li> </ul>	<ul style="list-style-type: none"> <li>☆正負極板是鉛鈣合金 Positive, negative's plates are all Calcium-Lead alloy.</li> <li>☆塑殼是防火 ABS 或等級是 UL 94V-0 L.O.I &gt;28%</li> <li>The plastic material is fire-resistance ABS or same grade of UL 94V-0 L.O.I &gt;28%</li> <li>☆組立用螺絲採用 M8 螺絲，扭力從 10N-m 至 12N-m(最大)採用不銹鋼材質，堅固耐用。 Assembling screws using M8 screws, torque from 10N-m to 12N-m (maximum) made of stainless steel, durable.</li> </ul>

放電特性(25°C) Discharge characteristic at different rates(25°C)	定電壓充電(25°C) Charging Characteristics	浮充期待壽命 Float Service Life

溫度與充電電壓關係 Relationship Between Temperature And Charging Voltage	容量保持性與溫度關係 Capacity Retention Characteristic	壽命循環關係 Cycle Service Life