

# 閥調式鉛酸蓄電池(VRLA)

## PMU2600 (2V600AH)

### 規格 Type

額定電壓 Rated Voltage	2V	
額定容量 Rated Capacity	600.0AH/10Hr/1.80V	端子 Terminal: 螺栓(M8 Bolt)
尺寸 Dimension	長度 Length	301±1mm(11.85in)
	寬度 Width	175±1mm(6.89in)
	高度 Height	331±1mm(13.03in)
	總高度 Total Height	367±1mm(14.45in)
重量 Weight	36.5kg(80.3Pounds)	
電槽材質 Container Material	ABS, UL 94V-0 or UL 94-HB 抗酸、抗油、防震 Resist acid, resist oil, resist vibration	氧氣指數 Index of oxygen L.O.I>28%
電解液型式 Type of electrolyte	AGM 不外漏 Non-spillable	



### 特性 Properties

容量 Capacity 25°C(77°F)	10 小時率 10HR of 60.0A to 1.80V	600.0AH
	5 小時率 5HR of 102.0A to 1.80V	510.0AH
	1 小時率 1HR of 318.0A to 1.80V	318.0AH
	0.5 小時率 0.5HR of 468.0A to 1.80V	234.0AH
內阻 Internal Resistance (at 1KHz)	完全充電 Full Charge at 25°C(77°F)	大約 Approx.0.46mΩ
容量受溫度影響 The capacity will be effected by temperature	40°C(104°F)	105%(10HR to 630AH)
	25°C(77°F)	100%(10HR to 600AH)
	0°C(32°F)	85%(10HR to 510AH)
	-20°C(-4°F)	60%(10HR to 360AH)
自我放電 Self-discharge	180 天後不到 15%，可以在 20°C (68°F) 下保存 10 個月；使用前需要完全充電。 Less than 15% after 180 days, it can be stored at 20°C (68°F) for 10 months; it needs to be fully charged before use.	
最大放電電流 5 秒 Maximum Discharge Current at 5 Sec	2700.0A(4.5CA)	
浮充 Float Charging	電壓 Voltage	2.275±0.025V 25°C(77°F)
	電流 Current	180.0A(0.3CA)
循環充電 Cyclic Charging	電壓 Voltage	2.40±0.05V 25°C(77°F)
	電流 Current	150.0A(0.25CA)
操作溫度 Operation Temperature Range	充電 Charge/放置 Storage:-15~40°C(5~104°F) · 放電 Discharge:-20~50°C(-4~122°F)	
期待壽命 Expected Life	25°C(77°F) 10~12 years	

### 尺寸 Dimension: inch (mm)

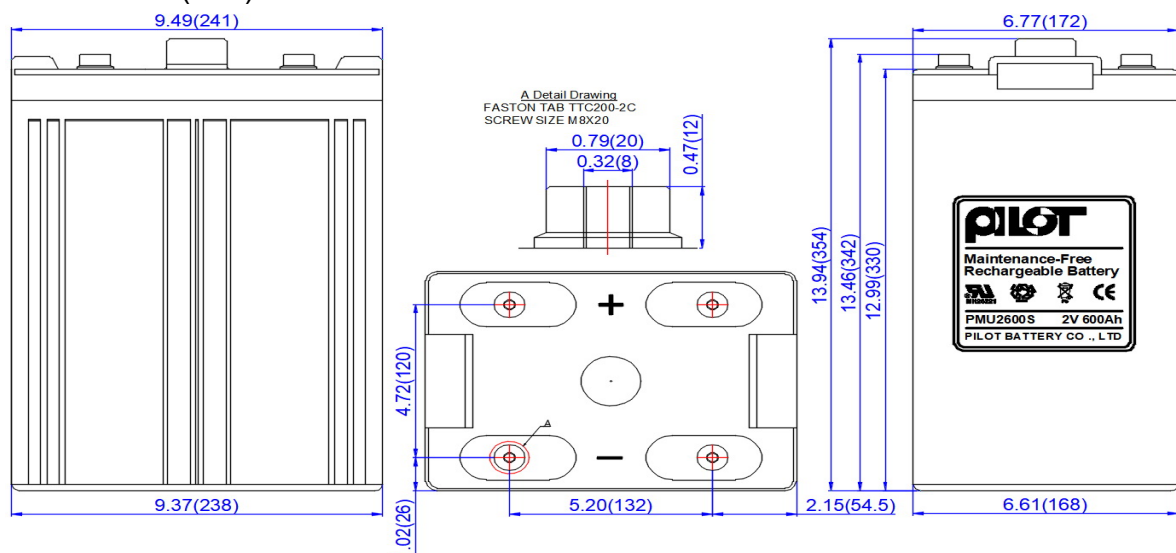

# PMU2600 PROPERTIES

Amperes and watts per battery at 25°C (77°F)

F.V.	Time	Minutes				Hours						
	Item	30	35	40	45	1	2	3	4	5	8	10
1.60	A	645.0	588.0	540.0	480.0	388.8	230.4	171.6	136.8	114.6	81.0	66.6
	W	1151	1073	990	884	725	440	328	262	220	157	129
1.65	A	613.8	552.0	504.0	456.0	378.6	222.0	164.4	132.0	113.4	79.2	65.4
	W	1122	1015	931	846	711	425	316	255	220	153	127
1.70	A	597.0	528.0	486.0	444.0	364.8	218.4	160.8	130.8	111.6	76.8	63.6
	W	1099	975	907	838	688	418	310	252	216	149	124
1.75	A	517.2	504.0	456.0	420.0	336.0	211.2	159.0	128.4	108.0	75.0	62.4
	W	961	943	855	789	637	404	307	249	190	146	122
1.80	A	468.0	450.0	432.0	390.0	318.0	196.8	150.0	122.4	102.0	72.0	60.0
	W	872	842	812	736	606	380	291	238	198	141	118
1.83	A	420.0	390.0	360.0	330.0	292.8	186.0	139.2	112.8	94.8	66.0	56.4
	W	798	744	693	640	563	363	272	221	186	129	112

用途 Application	密封結構 Seal construction	穩定性 Stabilities
<ul style="list-style-type: none"> <li>☆廣播電視系統 Broadcast television systems</li> <li>☆電信和 UPS 系統 Telecom and UPS systems</li> <li>☆通信系統 Communication back-up systems</li> <li>☆太陽能儲備系統 Solar storage power systems, wind power systems</li> <li>☆電力系統 Power systems</li> <li>☆緊急照明 Emergency lighting</li> <li>☆火災安全系統 Fire and security systems</li> </ul>	<ul style="list-style-type: none"> <li>☆沒有漏酸的危險，氣體釋放率超低，不需加水，能防止電解液乾枯或產生層化現象(於放電時)再組合率大於 98%</li> <li>Non-spillable, no leaking danger, the gas consumption rate is low, no need to replenish water, can avoid acid lack or crystallization problem during discharge, the recombination rate is higher than 98%</li> <li>☆極柱採用鉛錫合金或合金銅鍍鉛材質 The polarities adopted Antimony-Lead alloy or copper alloy covered with Lead material.</li> </ul>	<ul style="list-style-type: none"> <li>☆正負極板是鉛鈣合金 Positive, negative's plates are all Calcium-Lead alloy.</li> <li>☆塑殼是防火 ABS 或等級是 UL 94V-0 L.O.I &gt;28%</li> <li>The plastic material is fire-resistance ABS or same grade of UL 94V-0 L.O.I &gt;28%</li> <li>☆組立用螺絲採用 M8 螺絲，扭力從 10N-m 至 12N-m(最大)採用不銹鋼材質，堅固耐用。 Assembling screws using M8 screws, torque from 10N-m to 12N-m (maximum) made of stainless steel, durable.</li> </ul>

放電特性(25°C) Discharge characteristic at different rates(25°C)	定電壓充電(25°C) Charging Characteristics	浮充期待壽命 Float Service Life
---	---	------------------------------

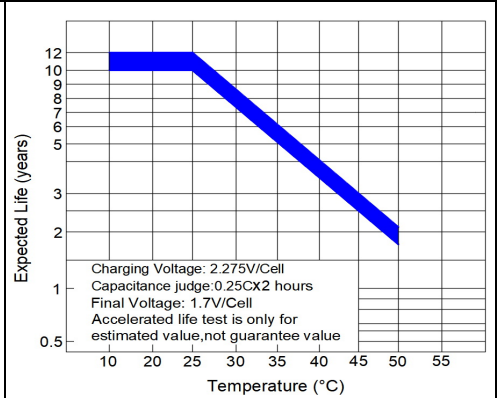
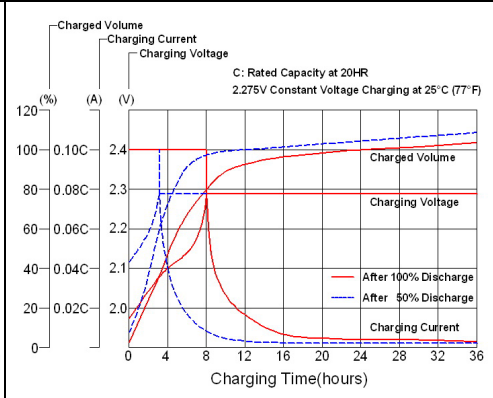
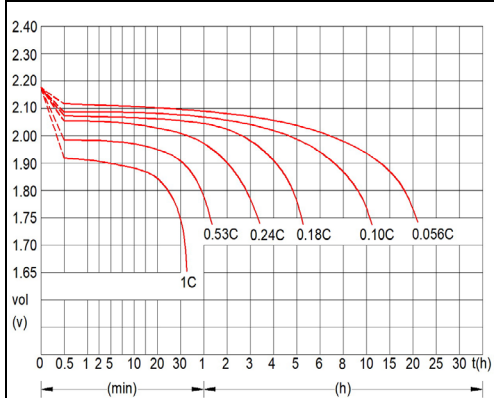

溫度與充電電壓關係 Relationship Between Temperature And Charging Voltage	容量保持性與溫度關係 Capacity Retention Characteristic	壽命循環關係 Cycle Service Life
--	---	------------------------------

